



Pompe centrifughe multistadio orizzontali **autoa-descanti**. Adatte alla movimentazione di liquidi non carichi; sistemi di pressurizzazione; irrigazione; acque potabili o con glicole in soluzione; trattamento acque; industria alimentare; riscaldamento e condizionamento; sistemi di lavaggio.

Stainless steel multistage horizontal **self-priming** pumps. Pumping of clean non-loaded fluids; pressurizing system; irrigation; drinking and glycol water; water treatment; heating and air conditioning; washing system.

Bombas centrífugas multietapas horizontales **autocebantes**. Bombeo de líquidos químicamente y mecánicamente no agresivos; sistemas de pressurización; riegos; agua potable o con glycol; tratamientos del agua; industria alimenticia; calefacción y refrigeración; sistemas de lavado.

Vícestupňová horizontální **samonasávací** čerpadla z nerezové oceli. Vhodná pro čerpání čistých kapalin; tlakové systémy; zavlažování; pitnou a glykolovou vodu; úpravu vody; vytápění a klimatizace; mycí stanice.

CARATTERISTICHE COSTRUTTIVE / CONSTRUCTION FEATURES CARACTERÍSTICAS CONSTRUCTIVAS / KONSTRUKČNÍ CHARAKTERISTIKY

Corpo pompa	acciaio cromo-nichel AISI 304
Pump body	stainless steel AISI 304
Cuerpo bomba	acero cromo-níquel AISI 304
Těleso čerpadla	nerezová ocel AISI 304
Supporto motore	alluminio
Motor bracket	aluminium
Soporte motor	aluminio
Držák motoru	hliník
Giranti, diffusori	acciaio cromo-nichel AISI 304
Impellers, diffusers	stainless steel AISI 304
Rodetes, difusores	acero cromo-níquel AISI 304
Oběžné kola, difuzory	nerezová ocel AISI 304
Tenuta meccanica	ceramica-grafite
Mechanical seal	ceramic-graphite
Sello mecánico	cerámica-grafito
Mechanická ucpávka	keramika-grafit
Albero motore	acciaio cromo-nichel AISI 303
Motor shaft	stainless steel AISI 303
Eje motor	acero cromo-níquel AISI 303
Hřídel motoru	nerezová ocel AISI 303
Temperatura del liquido	
Liquid temperature	-15 ÷ +110 °C
Temperatura del líquido	
Teplota média	
Pressione di esercizio	
Operating pressure	max 7 bar
Presión de trabajo	
Pracovní tlak	

MOTORE / MOTOR / MOTOR / MOTOR

Motore 2 poli a induzione	3~ 230/400V-50Hz
2 pole induction motor	1~ 230V-50Hz (con termostato fino a 1,85kW with thermal protection up to 1,85 kW con protección térmica hasta 1,85 kW s tepelnou ochranou do 1,85 kW)
Motor de 2 polos a inducción	
2-pólový indukční motor	
Classe di isolamento	
Insulation class	F
Clase de aislamiento	
Izolační třída	
Grado di protezione	
Protection degree	IP44
Grado de protección	
Krytí	

U 3 S A - 100/5 T

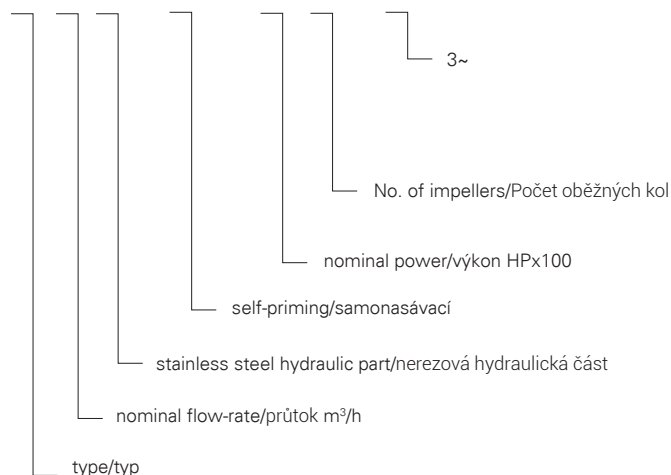

3 SA

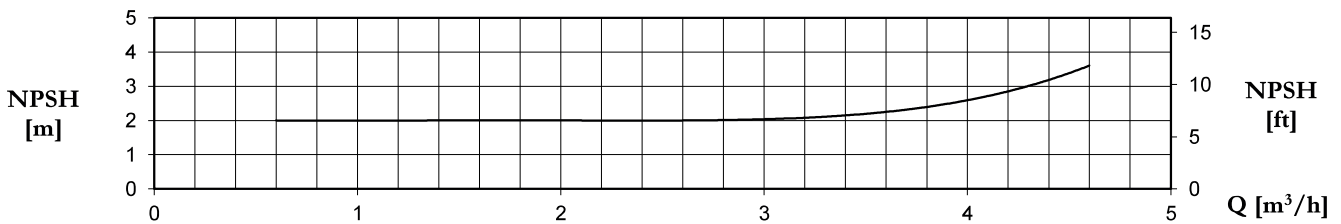
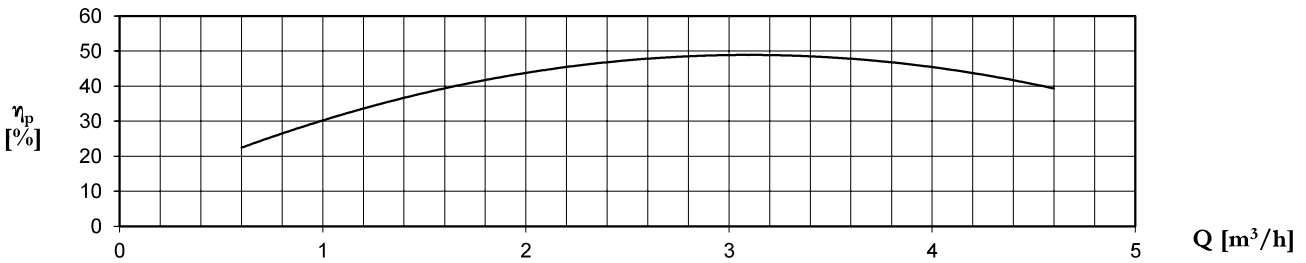
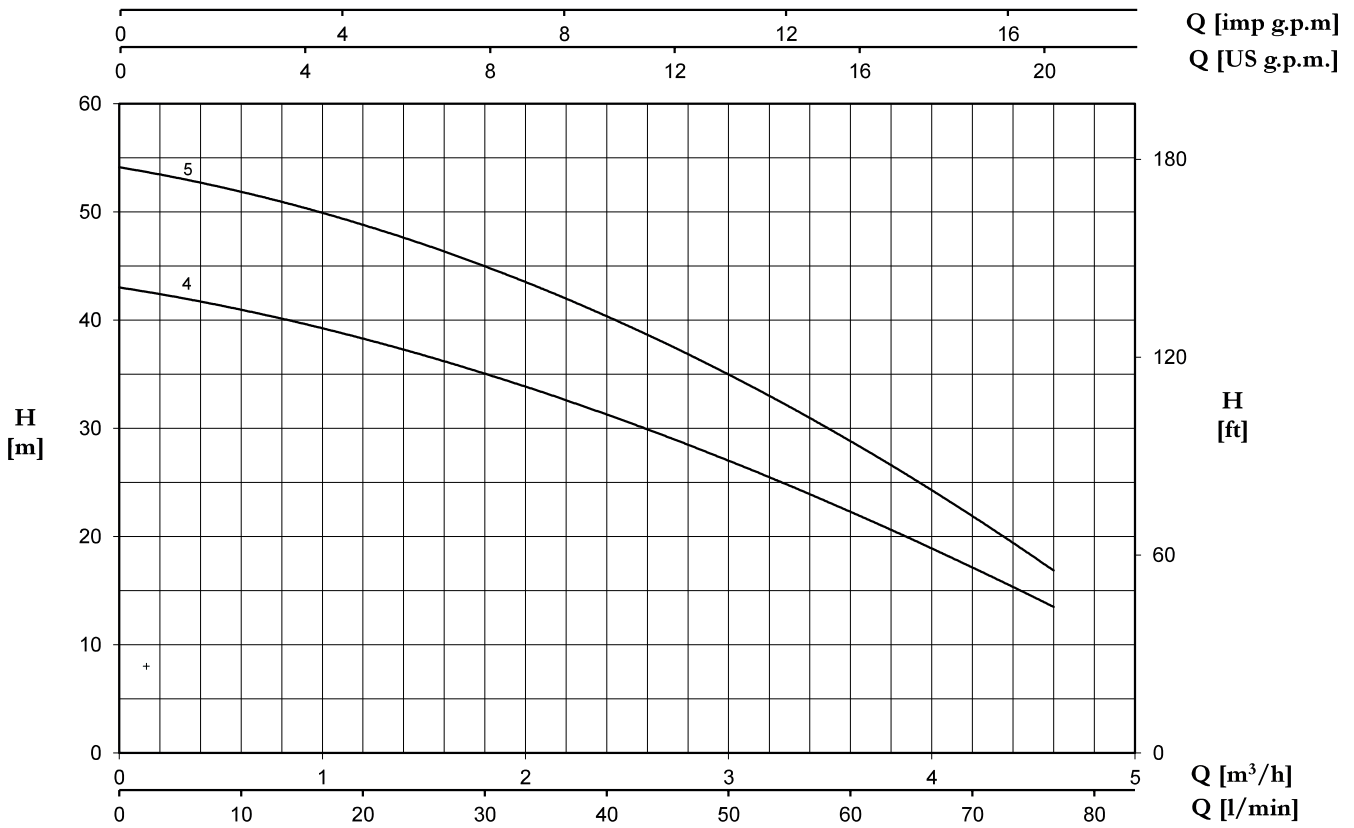

TYPE/TYP		P2		P1 (kW)		PROUD		Q (m³/h - l/min)						
1~	3~					1~	3~	0	0,6	1,2	1,8	2,4	3,6	4,6
		(HP)	(kW)	1~	3~	1x230 V 50 Hz	3x400 V 50 Hz	H (m)						
U 3SA-90/4	U 3SA-90/4T	0,9	0,66	0,83	0,8	3,6	1,7	43,0	41,0	38,3	35,0	31,3	22,3	13,5
U 3SA-100/5	U 3SA-100/5T	1	0,75	0,99	0,92	4,4	1,7	54,0	52,1	48,8	44,9	40,2	29,0	16,8

ULTRA SA

5 SA

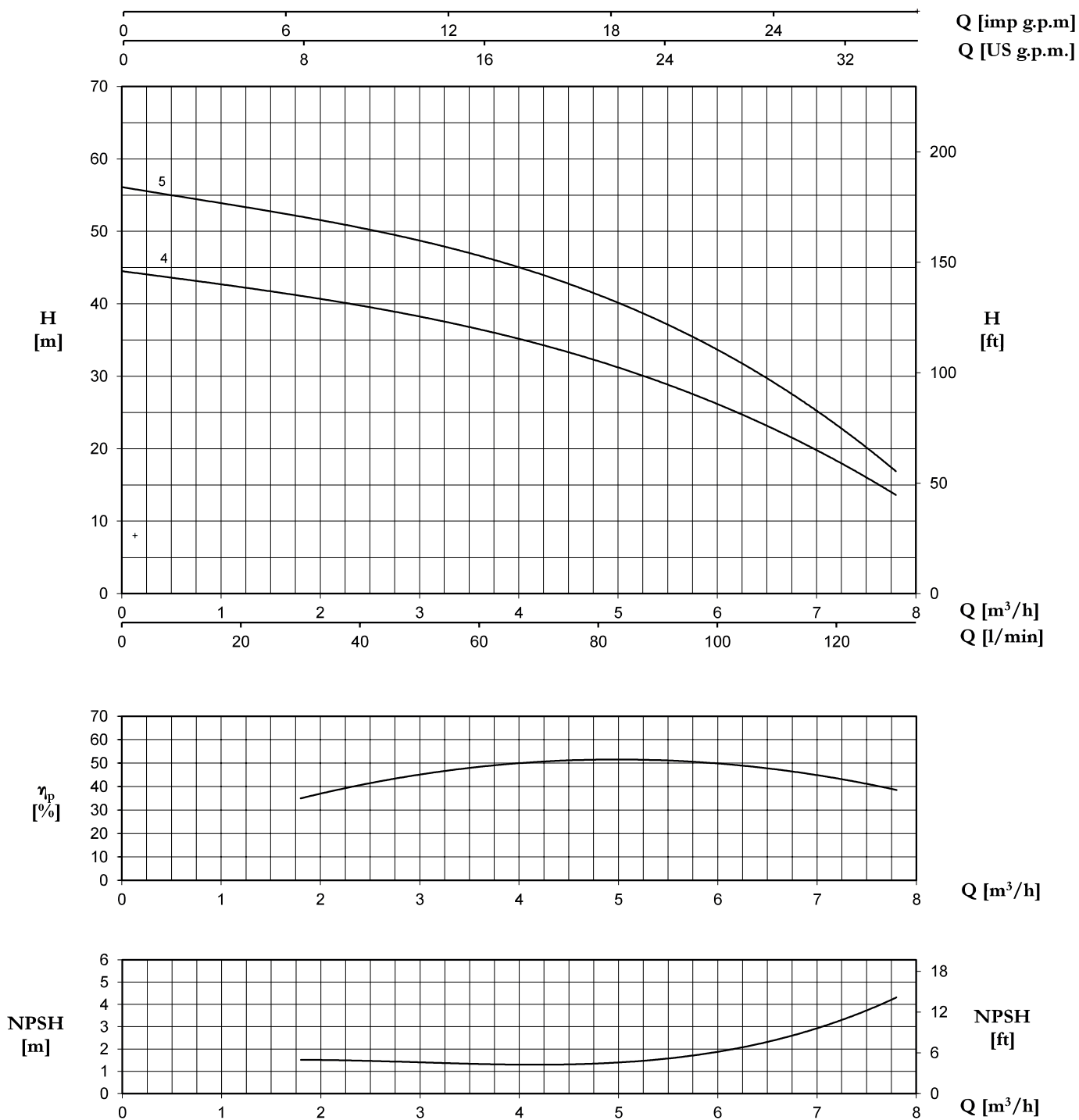

TYPE/TYP		P2		P1 (kW)		PROUD		Q (m³/h - l/min)							
1~	3~					1~	3~	0	1,8	2,4	3,6	4,8	6	7,2	7,8
		0	30	40	60			80	100	120	130				
		(HP)	(kW)	1~	3~	1x230 V 50 Hz	3x400 V 50 Hz	H (m)							
U 5SA-120/4	U 5SA-120/4T	1,2	0,9	1,09	1,08	4,9	2,4	44,5	41,0	40,0	36,4	32,0	26,2	18,5	13,5
U 5SA-150/5	U 5SA-150/5T	1,5	1,1	1,39	1,31	6,5	2,7	56,0	52,4	50,5	46,4	41,0	33,8	23,8	16,5

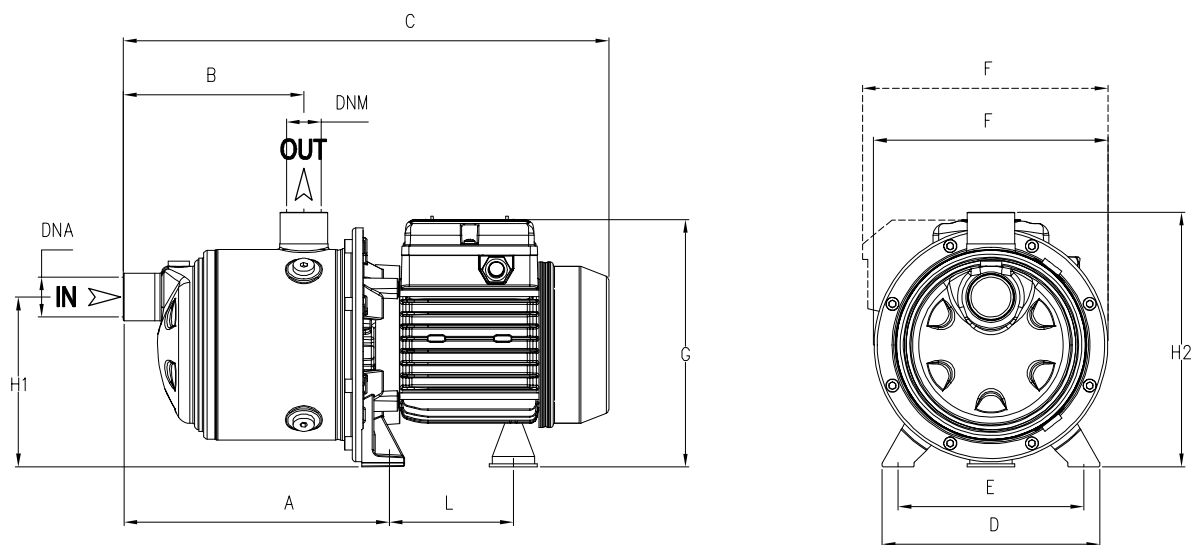

TYPE/TYP	DIMENSIONS/ROZMĚRY (mm)										Kg	DNA	DNM
	A	B	C	D	E	F	G	L	H1	H2			
U 3SA-90/4	190,8	175,0	405,0	164,0	140,0	178,0	190,0	93,7	128,0	192,0	9,6	1" G	1" G
U 3SA-100/5	214,8	199,0	452,0	164,0	140,0	178,0	203,0	104,7	128,0	192,0	12,2		
U 5SA-120/4	190,8	175,0	428,0	164,0	140,0	178,0	203,0	104,7	128,0	192,0	12,3		
U 5SA-150/5	214,8	199,0	484,0	164,0	140,0	201,0	211,0	128,2	134,0	198,0	15,1		