

# CPS10/DHR

## AUTOMATICKÉ TLAKOVÉ STANICE S FREKVENČNÍM MĚNIČEM

### VÝKONNOSTNÍ KŘIVKA

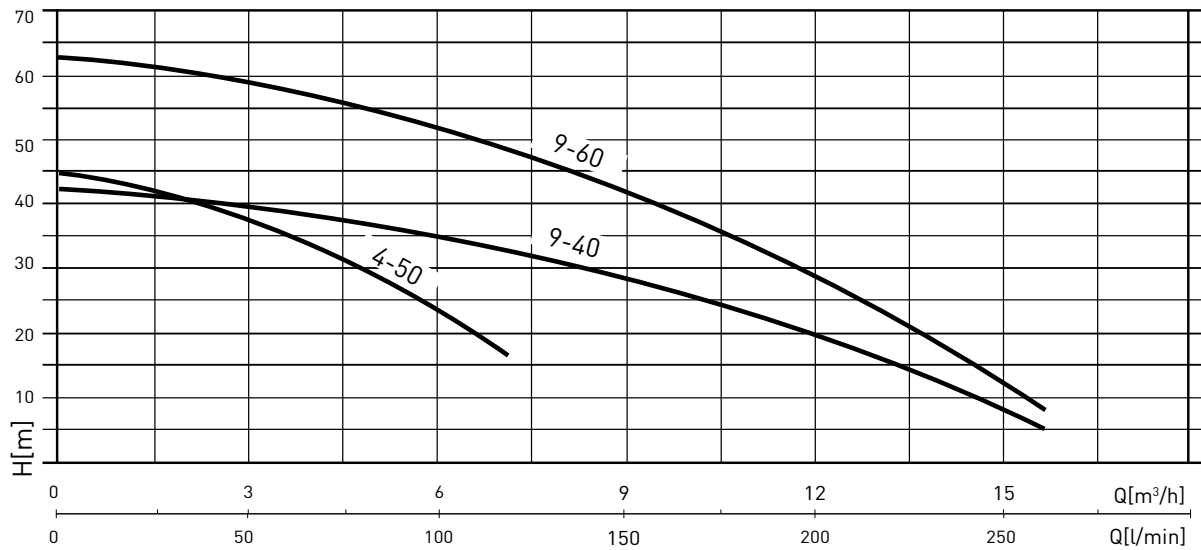

### VÝKONNOSTNÍ TABULKA

MODEL	P2		VOLT. (V)	In (A)	Q	Q											
	HP	kW				l/min	0	40	60	80	100	120	160	200	240	260	
						m³/h	0	2,4	3,6	4,8	6	7,2	9,6	12	14,4	15,6	
CPS10/DHR 4-50	1,5	0,9	1~230	9,1	m.c.w.	44	39	35	30	24	17						
CPS10/DHR 9-40	1,74	1,3	1~230	12,5		41,5	40	39	38	35	33	27	19	10	5		
CPS10/DHR 9-60	2,4	1,8	1~230	15,8		62	60	58	56	52	49	40	29	14	6		

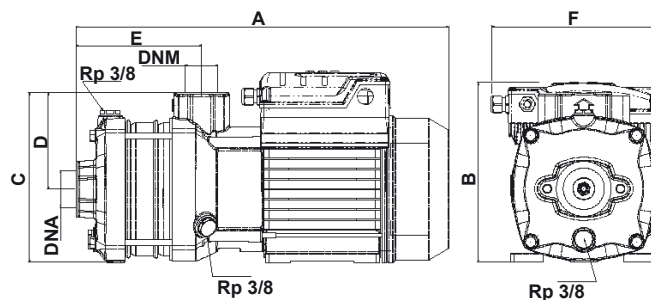

### TABULKA ROZMĚRŮ A HMOTNOSTÍ

MODEL	Rozměry mm.								Váha Kg
	A	B	C	D	E	F	DNA	DNM	
CPS10/DHR 4-50	445	225	155	65	190	232	1" 1/4	1"	18
CPS10/DHR 9-40	408	215	185	105	137	232	1" 1/4	1" 1/4	21,1
CPS10/DHR 9-60	468	215	185	105	198	232	1" 1/2	1" 1/4	26