

# CPS10/DHI

## AUTOMATICKÉ TLAKOVÉ STANICE S FREKVENČNÍM MĚNIČEM

### VÝKONNOSTNÍ KŘIVKY

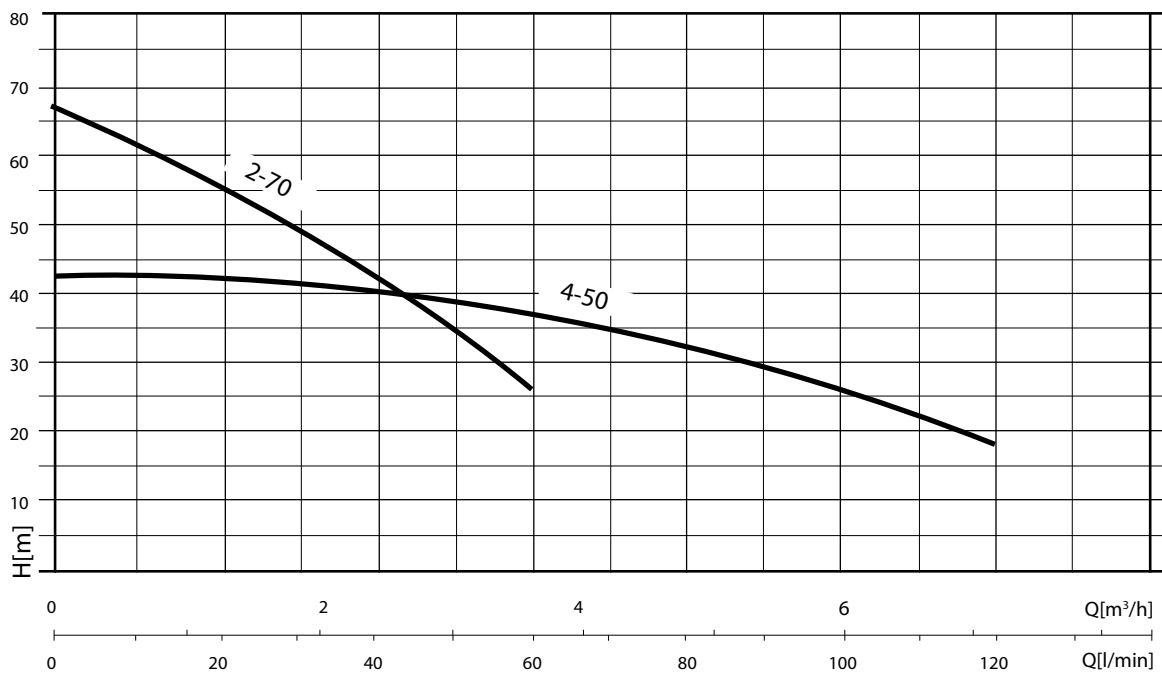

### VÝKONNOSTNÍ TAKULKA

Varianta	P2		[V]	In [A]	0	Flow Rate											
	HP	kW				l/min	0	10	20	30	40	50	60	80	100	120	
CPS10/DHI 2-70	1,25	0,9	1~230	10,6	Výška	68	63	57	50	43	35	26					
CPS10/DHI 4-50	1,25	0,9	1~230	10,6		43				42	39	36	33	27	18		

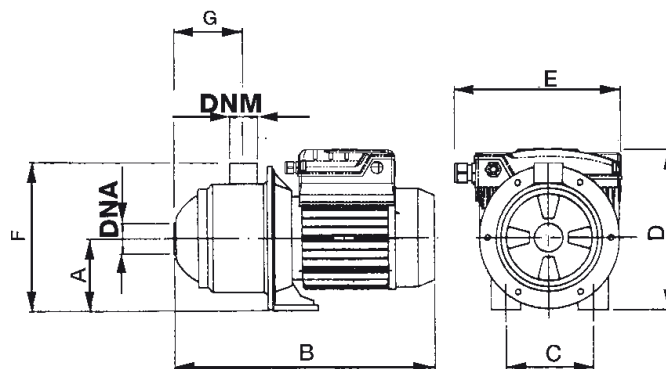

### TABULKA ROZMĚRŮ A HMOTNOSTÍ

Varianta	Rozměry [mm]										Hmotnost [Kg]
	A	B	C	D	E	F	G	DNA	DNM		
CPS10/DHI 2-70	105	460	141	245	232	235	135	1" 1/4	1" 1/4	17,4	
CPS10/DHI 4-50	105	460	141	245	232	235	135	1" 1/4	1" 1/4	17,4	